

Output Voltage PID F7 Drive Software Technical Manual



Software Number: VSF11018X, Drive Models: CIMR-F7UXXXXXX-061
Document Number: TM.F7SW.061, Date: 05/05/05, Rev: 05-05

This document is intended to provide proper installation and use of the Yaskawa drive with custom software. This document is a supplement to the standard drive technical manual. It describes the effects on the drive parameters and functions with the software installed. Read and understand this document and the standard drive technical manuals before attempting to install, adjust, operate, inspect or maintain the drive. **Observe all cautions and warnings in this document and the standard drive technical manuals.** Custom software is written to add functionality to a standard AC drive to enhance or enable use in a specific application. The software is loaded to the flash ROM area of the control board, and replaces the standard drive software. Custom software can add new functions, modify standard functions, or even inhibit standard functions. It can be used to modify display text or parameter names. Custom software is usually loaded to the drive before delivery. The control board and drive nameplate are assigned unique part numbers and the software is registered, archived, and retrievable.

When seeking support for a drive with custom software, it is imperative to provide the unique part number shown on the drive nameplate. The software has been flashed to the control board memory and the operation of parameters, functions, and monitors are different than the standard drive software, as described herein.

1.0 Overview

This Output Voltage PID software allows an F7 drive to control its output voltage independent of its frequency. The software was created for the following applications: Uninterruptible Power Supply (UPS), Marine Power Supply, Medical Power Supply (CT and MRI), and Vibratory Welder.

An independent PID controller is added, the output of which will trim the output voltage. This is useful for regulating the voltage on the output side of a sinusoidal filter. The trim range for the PID controller is +13% to -100%. Two additional dynamic compensation functions are also added for RMS current (Iac) and secondary current (Iq).

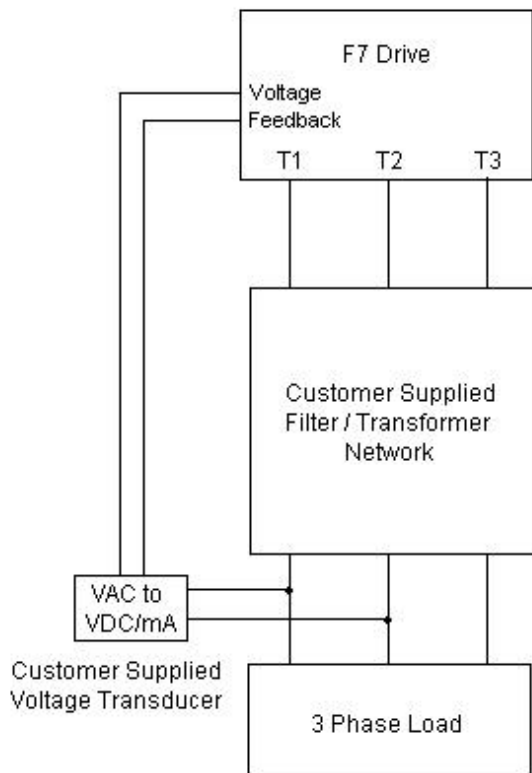

Application Example of Output Voltage PID

2.0 Changes from Standard Product

- The energy savings function (B8-01 = 1) cannot be used in conjunction with the output voltage PID controller in the V/Hz control method (A1-02 = 0) or an “OPE12 - Energy Save ON” fault will occur.
- Parameters N9-10, N9-14, and N9-15 have been moved from the “Factory” access level to the “Advanced” access level (A1-01) in the V/Hz control mode (A1-02 = 0) for easier access. The factory should be consulted before adjusting these parameters.

3.0 Limitations

- The output voltage PID controller is available only in the V/Hz control mode (A1-02 = 0).
- The “P” group parameters cannot be used in the “User Access Level” (A1-03 = 1110).
- This software is specifically designed for the applications described in section 1. ***This software should not be used to control a motor.***

4.0 Related Parameters and Functions

4.1 Parameters

Parameter Number	Modbus Address	Parameter Name <i>Digital Operator Display</i>	Description	Range	Default	Change During Run	Control Mode *1			
							V/f	V/f w/ PG	Open Loop Vector	Flux Vector
N9-10	5D9h	Automatic Voltage Regulator Time AVR Time	Sets the time constant of the Automatic Voltage Regulator (AVR). The AVR regulates the drive's output voltage by compensating for changes in the DC bus voltage (input drive voltage).	0.0 ~ 100.0 msec	1.0	No	A*2	F	F	F
N9-14	5DDh	Power Factor Angle Filter 1 Pwr Angle Flt 1	Sets the filter time of power factor angle detection function used during acceleration.	0 ~ 1000 msec	5	No	A*2	F	-	-
N9-15	5DEh	Power Factor Angle Filter 2 Pwr Angle Flt 2	Sets the filter time of power factor angle detection function used during constant frequency output (speed agree).	0 ~ 1000 msec	5	No	A*2	F	-	-
P1-01	600h	Output Voltage Setpoint Output V Setpt	Sets the target value of the Output Voltage PID controller. The drive's output voltage will be modulated to keep the analog input “output voltage feedback” signal equal to this setpoint. <i>Note: A setting of 0.0VAC disables the Output Voltage PID controller.</i>	0.0 ~ 600.0 VAC	460.0	Yes	A	-	-	-

*1: Access Level (A1-01): Q = “Quick Start”, A = “Advanced”, F = “Factory”.

*2: Moved from the “Factory” access level to the “Advanced” access level. Consult the factory before adjusting.

4.1 Parameters (continued)

Parameter Number	Modbus Address	Parameter Name <i>Digital Operator Display</i>	Description	Range	Default	Change During Run	Control Mode *1			
							V/f	V/f w/ PG	Open Loop Vector	Flux Vector
P1-02	601h	Output Voltage PID Gain Output V Gain	Sets the proportional gain of the output voltage PID controller. A larger setting equals more response. <i>Note: A setting of 0.00 disables this feature.</i>	0.0 ~ 25.00	1.00	Yes	A	-	-	-
P1-03	602h	Output Voltage PID Integral Time Output V I Time	Sets the integral time of the output voltage PID controller. A smaller setting equals more response. <i>Note: A setting of 0.00sec disables this feature.</i>	0.00 ~ 360.00 sec	1.00	Yes	A	-	-	-
P1-04	603h	Output Voltage PID Integral Limit Output V I Lmt	Sets the limit of the output voltage PID integrator. <i>Note: 100% = Voltage reference from V/Hz pattern.</i>	0.0 ~ 100.0 %	100.0	Yes	A	-	-	-
P1-05	604h	Output Voltage PID Derivative Time Output V Deriv T	Sets the derivative time of the output voltage PID controller. A larger setting equals greater response. <i>Note: A setting of 0.00 sec disables this feature.</i>	0.00 ~ 10.00 sec	0.00	Yes	A	-	-	-
P1-06	605h	Output Voltage PID Limit Output V Limit	Sets the overall limit of the output voltage PID controller (P + I + D). <i>Note: 100% = Voltage reference from V/Hz pattern.</i>	0.0 ~ 100.0 %	100.0	Yes	A	-	-	-
P1-07	606h	Analog Input Full Scale Voltage Ana Full Scale V	Sets the scaling for the multi-function analog input function "Output Voltage Feedback" (H3-0X = 20). <i>Note: 10VDC / 20mA feedback = P1-07</i>	0.0 ~ 1000.0 VAC	600.0	No	A	-	-	-

*1: Access Level (A1-01): Q = "Quick Start", A = "Advanced", F = "Factory".

*2: Moved from the "Factory" access level to the "Advanced" access level. Consult the factory before adjusting.

4.1 Parameters (continued)

Parameter Number	Modbus Address	Parameter Name <i>Digital Operator Display</i>	Description	Range	Default	Change During Run	Control Mode *1			
							V/f	V/f w/ PG	Open Loop Vector	Flux Vector
P2-01	60Ah	RMS Output Current (I _{ac}) Compensation <i>I_{ac} RMS Comp V</i>	Sets the amount of voltage compensation when the RMS output current is 100%. <i>Note: A setting of 0.0VAC disables this feature.</i>	0.0 ~ 200.0 VAC	0.0	Yes	A	-	-	-
P2-02	60Bh	Output Current (I _{ac}) Compensation Filter Time <i>I_{ac} RMS FilTime</i>	Sets the 1 st order filter time on the RMS output current (I _{ac}) compensation feedback. A smaller setting equals more response but less stability.	0.01 ~ 1.00 sec	0.01	Yes	A	-	-	-
P2-03	60Ch	I _q Voltage Compensation <i>I_q Comp V</i>	Sets the amount of voltage compensation when the secondary current is 100%. <i>Note: A setting of 0.0VAC disables this feature.</i>	0.0 ~ 200.0 VAC	0.0	Yes	A	-	-	-
P2-04	60Dh	I _q Voltage Compensation Filter Time <i>I_q FilTime</i>	Sets the 1 st order filter time on the secondary current (I _q) compensation feedback. A smaller setting equals more response but less stability.	0.01 ~ 1.00 sec	0.01	Yes	A	-	-	-

*1: Access Level (A1-01): Q = "Quick Start", A = "Advanced", F = "Factory".

*2: Moved from the "Factory" access level to the "Advanced" access level. Consult the factory before adjusting.

5.2 Monitors (U1-XX)

Monitor Number	Modbus Address	Monitor Name Digital Operator Display	Description	Scaling for Multi-function Analog Output Terminals FM and AM (H4-01, H4-04)	Unit	Control Mode *1			
						V/f	V/f w/ PG	Open Loop Vector	Flux Vector
U1-90	720h	Voltage Feedback Voltage Feedback	Displays the analog input feedback sensor voltage. <i>Note: Scaled by P1-07.</i>	N/A	0.1 VAC	A	-	-	-
U1-91	721h	Voltage Error Voltage Error	Displays the difference between the voltage setpoint (P1-01) and the analog input voltage feedback.	100% = 100VAC	0.1 VAC	A	-	-	-
U1-92	722h	Output Voltage PID Output Voltage PID Out	Displays the contribution of the output voltage PID controller.	100% = 100VAC	0.1 VAC	A	-	-	-
U1-93	723h	RMS Output Current Compensation Level Iac Comp Voltage	Displays the contribution of the RMS output current (Iac) compensation function.	100% = 100VAC	0.1 VAC	A	-	-	-
U1-94	724h	Iq Voltage Compensation Level Iq Comp Voltage	Displays the contribution of the secondary current (Iq) compensation function.	100% = 100VAC	0.1 VAC	A	-	-	-

*1: Access Level (A1-01): Q = "Quick Start", A = "Advanced", F = "Factory".

4.3 Multi-function Analog Input Settings (H3-05, H3-09)

Setting	Description	Scaling for 100% Input (10VDC or 20mA)	Control Mode			
			V/f	V/f w/ PG	Open Loop Vector	Flux Vector
20	Output Voltage PID Controller Voltage Feedback Signal	100% = P1-07 Value	√	-	-	-

√: Available.

4.4 Faults

Fault Display	Description	Cause	Countermeasures
OPE12 Energy Save ON	The energy savings feature (B8 Group) was enabled at the same time the output voltage PID controller was enabled.	Energy savings was enabled (B8-01 = 1) when parameter P1-01 > 0.0 <i>Note: V/Hz control mode only (A1-02 = 0).</i>	Set B8-01 = 0 or P1-01 = 0.0VAC

5.0 Function Description

An independent PID controller is added, the output of which will trim the output voltage. The trim range is +13% to -100% of the output voltage as commanded by the V/Hz pattern. There are also two dynamic functions available that allow output voltage boost based upon the RMS output current (Iac) and the secondary (Iq) current. These are useful in regulating the output voltage during sudden load changes. These functions can each add up to 400VAC (200VAC for 240V drives) of additional voltage (limited by the input voltage to the drive).

The intent of this software is to control the voltage after a filter / transformer network; as the output of the drive is NOT used to drive a motor, but instead used operate as a power supply operating at a fixed frequency. An external customer-supplied transducer is required that converts the load terminal voltage into a 0-10VDC or 4-20mA analog signal, which is used as the feedback to the PID controller.

The multi-function digital input (H1-0X) functions that normally control the drive's standard PID controller (B5 group) also control the Output Voltage PID controller. These functions include: PID Disable (H1-0X = 19), PID Integral Reset (H1-0X = 30), and PID Integral Hold (H1-0X = 31).

6.0 Block Diagram

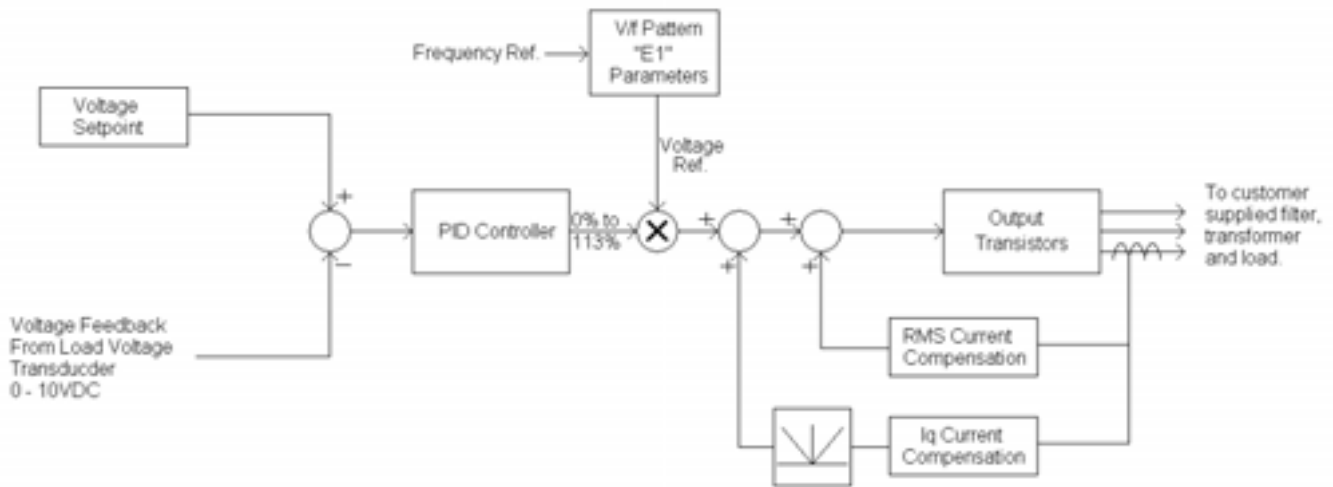

7.0 Typical Parameter Settings

7.1 Parameter Settings for a Typical Power Supply Application (480V Drive).

Parameter	Description	Setting
A1-02	Control Method	0 (V/F Control)
B1-01	Reference Source	0 (Keypad)
B1-03	Stopping Method	1 (Coast to Stop)
B1-04	Reverse Operation	1 (Disabled)
C1-01	Acceleration Time 1	0.20sec
C1-02	Deceleration Time 1	0.20sec
C2-01	S-curve Time 1	0.00sec
C2-02	S-curve Time 2	0.00sec
C2-03	S-curve Time 3	0.00sec
C4-01	Torque Compensation Gain	0.00
C6-01	Operation Duty Selection	1 (Normal Duty 1) *3
C6-02	Carrier Frequency Selection	3 (8.0kHz) *3
D1-01	Frequency Reference 1	60.00Hz
E1-03	V/F Pattern Selection	FF (Custom w/o Limit)
E1-05	Maximum Output Voltage	460VAC
H3-05	Terminal A3 Function Selection	20 (Output Voltage Feedback)
L2-01	Powerloss Detection Selection	2 (CPU Ride Through)
L2-03	Minimum Base Block Time	0.1sec
L2-04	Voltage Recovery Ramp Time	0.0sec
L2-05	Undervoltage Detection Level	150VDC *3
L3-01	Stall Prevention During Acceleration	0 (Disabled)
L3-04	Stall Prevention During Deceleration	0 (Disabled)
L3-05	Stall Prevention During Running	0 (Disabled)
L8-05	Input Phase Loss Selection	0 (Disabled)
L8-07	Output Phase Loss Selection	0 (Disabled)
N1-01	Hunting Prevention Selection	0 (Disabled)
N9-10	AVR Time Constant	100.0msec *4
N9-14	Power Factor Detection Time 1	1000.0msec *4
N9-15	Power Factor Detection Time 2	1000.0msec *4
P1-01	Output Voltage PID Setpoint	460VAC
P1-02	Output Voltage PID Gain	3.00
P1-03	Output Voltage PID Integral Time	0.30sec
P1-07	Output Voltage Feedback Scaling	(Sensor Dependent) VAC

*3: Changing these settings to the values shown may require either a higher capacity drive or additional hardware. Please consult the Industrial Applications department at Yaskawa before adjusting.

*4: Formerly factory access level parameters. Please consult the Industrial Applications department at Yaskawa before adjusting.